

# TUBE DIFFUSER Newair® HDPE

Components for water and wastewater treatment

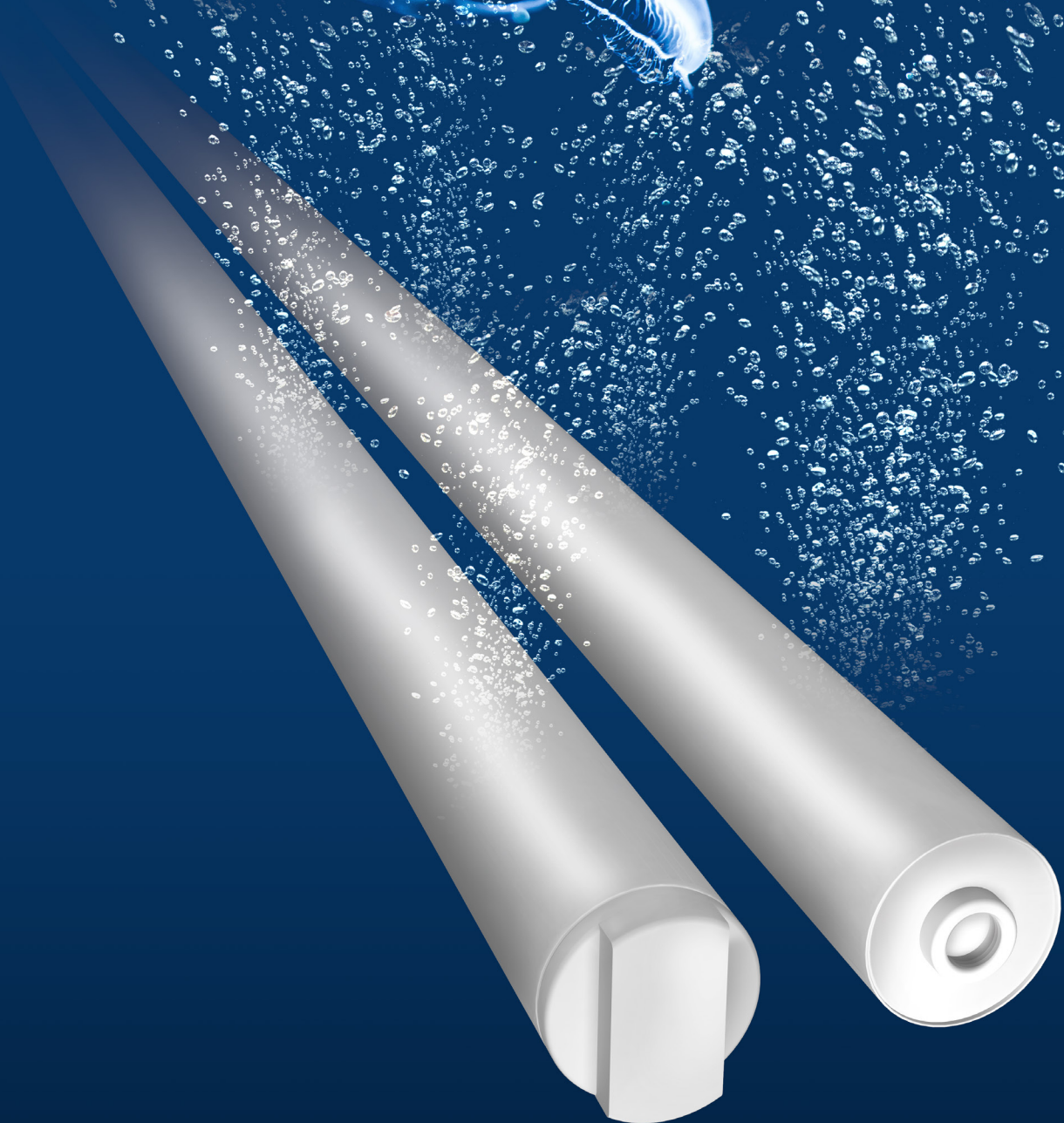



## PRODUCT PROPERTIES

- energy-saving
- low head loss
- high air flow
- high oxygen transfer
- break-proof easy to install
- very good chemical resistance
- abilities of operation: continuous
- approval (can be used for drinking water)
- applications:
  - municipal waste water
  - industrial waste water
  - general aeration feedings

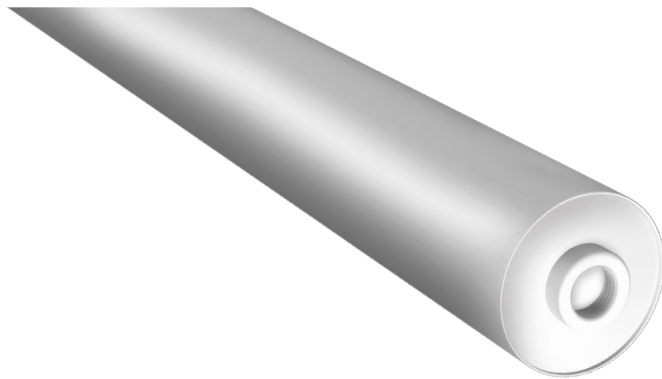

## NEWAIR® TUBE DIFFUSER, OPERATING RANGE

| Model   | Range flow rate (Nm <sup>3</sup> /h x ml) min-max | Optimal flow rate (Nm <sup>3</sup> /h x ml) | Thread connection Standard (3/4" female other up request) | Max temperature Celsius/ Fahrenheit | Operating procedure     | Application   |
|---------|---|---|---|-------------------------------------|-------------------------|---------------|
| NWA500  | 6-12  | 8   | 3/4" F  | 80°C/176°F                          | continuous intermittent | Aeration tank |
| NWA750  | 6-12  | 8   | 3/4" F  | 80°C/176°F                          | continuous intermittent | Aeration tank |
| NWA1000 | 6-12  | 8   | 3/4" F  | 80°C/176°F                          | continuous intermittent | Aeration tank |

| Manifold in PP, Connection thread 1" female | Air distributor square pipe in AISI 304 connection 2" female |
|---|--|
| NWA-1001<br>NWA-1501<br>NWA-2001<br>        | NWA-1002<br>NWA-1502<br>NWA-2002<br>                         |
| NWA-1003<br>NWA-1503<br>NWA-2003<br>        | NWA-1004<br>NWA-1504<br>NWA-2004<br>                         |
| NWA-1005<br>NWA-1505<br>NWA-2005<br>        |  |

Data are based on clean water 20°C temperature, 1013mbar / 68°F, 101,3kpa. All data are approximate data!

# Newair® HDPE

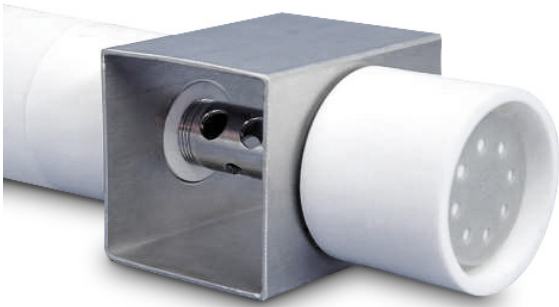

Oscillating non return valve, makes sure that the non return valve can not be blocked from any dirty.

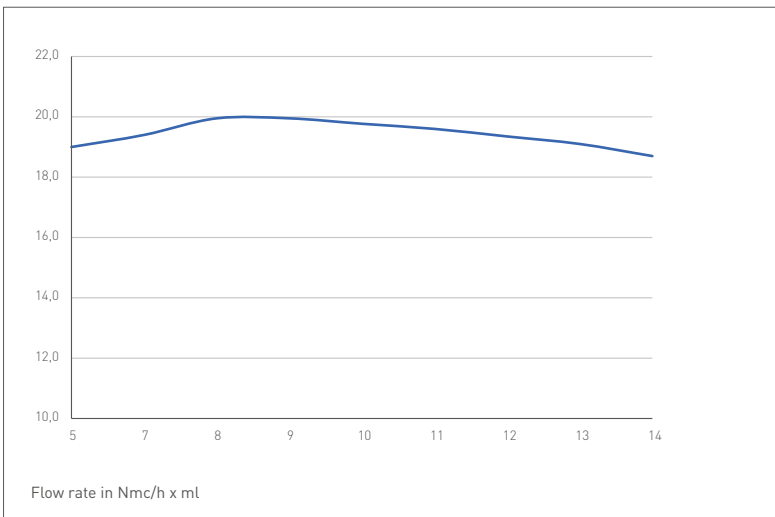

## NEWAIR® NWA TUBE DIFFUSER FINE BUBBLE OXYGEN TRANSFER EFFICIENCY

— Oxygen transfer rate O<sub>2</sub> in gr / Nmc \* m submersion

Data are referd to in clean tap water standard condition at 20°C, 101,3kPa

Example:  
Diffuser works with 9 Nmc/h and waterlevel above diffuser surface is 5 meter, then consider:  
 $20\text{gr/Nmc} \times \text{m} * 9\text{Nmc/h} * 5\text{m} = 900\text{gr/h}$

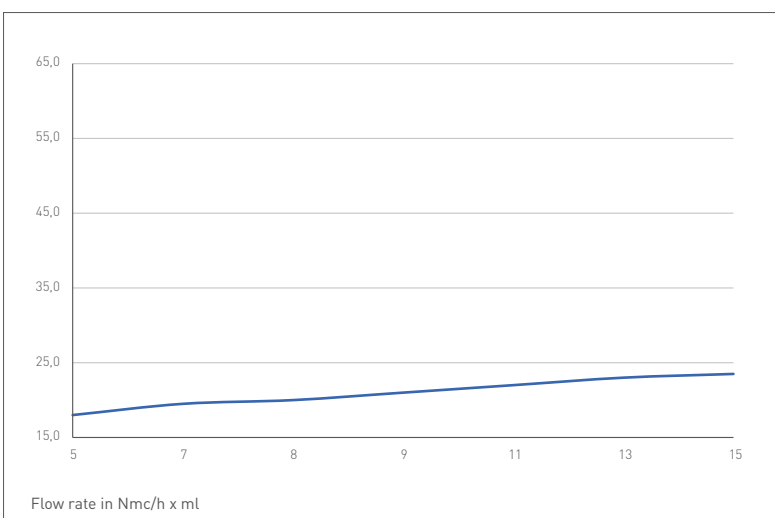

## NEWAIR® NWA TUBE DIFFUSER FINE BUBBLE HEAD LOSS

— Head loss in mbar (incl. check valve)

Data are referd to in clean tap water standard condition at 20°C, 101,3kPa

Comparable values can only be obtained with a similar setup and condition. Depending on the tank geometry, slit chart, water depth and planar allocation, the quoted values can change. All the data are based on clean water 20° temperature, 1013mbar / 68°F, 101,3kpa. All data are approximate data!

## INSTALLATION DRAWING

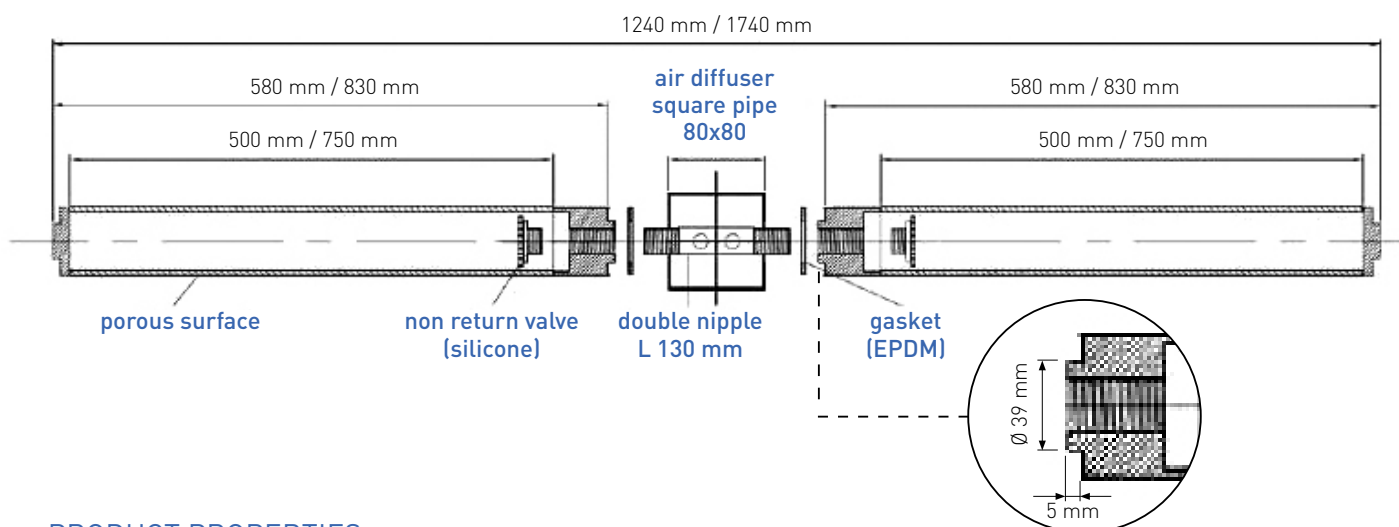

## PRODUCT PROPERTIES

| Number                   | HDPE                                 |
|--------------------------|--------------------------------------|
| Colour                   | white                                |
| Wall thickness           | 5,2 mm                               |
| Density                  | 0,97 g/cm <sup>2</sup>               |
| Chemical resistance      | high                                 |
| Pore size at the inside  | 350 µm                               |
| Pore size at the outside | 120 µm                               |
| Operating temperature    | 0 - 80°C                             |
| Application              | municipal and industrial waste water |

## STANDARD DIMENSIONS

| Aerator length [mm] | Total length [mm] | Tube diameter [mm] | Aeration area [m <sup>2</sup> ] | Adapter           | Total weight [g] |
|---------------------|-------------------|--------------------|---------------------------------|-------------------|------------------|
| 500                 | 580               | 72                 | 0,11                            | ¾ internal thread | 570              |
| 750                 | 830               | 72                 | 0,17                            | ¾ internal thread | 760              |
| 1000                | 1080              | 72                 | 0,23                            | ¾ internal thread | 950              |

## SPECIAL DIMENSIONS

|                        |  |
|------------------------|--|
| Possible lengths       | 100 1000 mm                                    |
| Possible adapter forms | ½ , ¾ , 1 , 1 ¼ internal thread and on request |

All data are approximate data!

# Newair® HDPE

## FUNCTION CHART OF THE PORE STRUCTURE

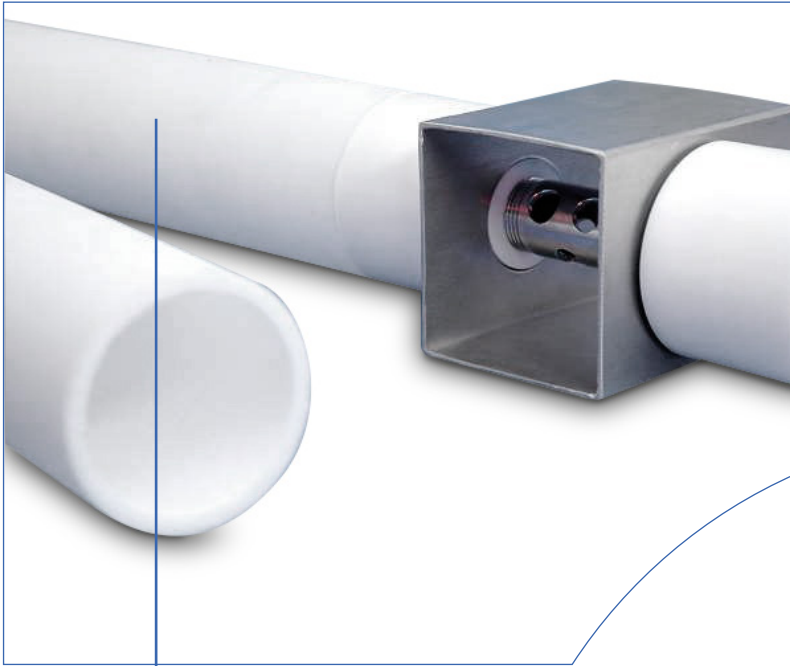

THE NEWAIR AERATOR IS CHARACTERIZED BY A SPECIAL MATERIAL STRUCTURE

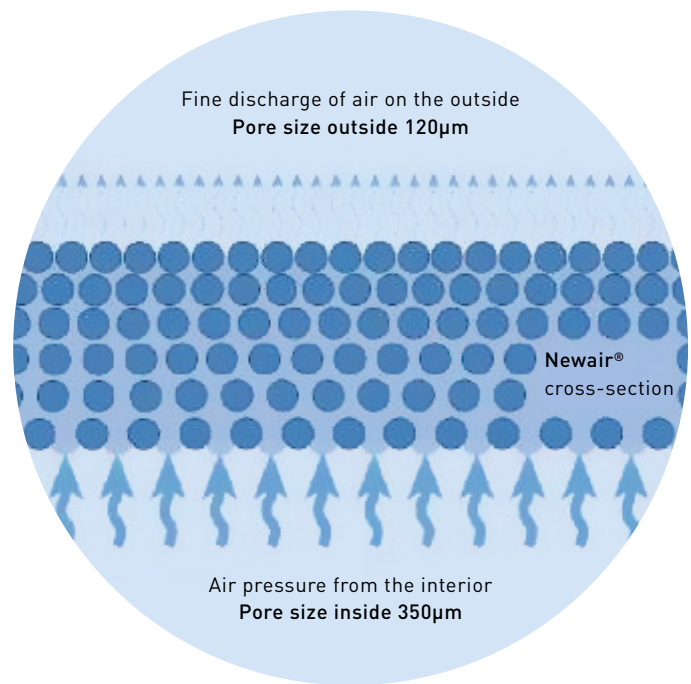

The newair aerator is characterized by a special material structure. The size of the pores reducing in flow direction. On the one hand there will be created a

huge upstream flow area for the air, on the other hand there will be reached a fine allocation of the bubbles by a small pore size on the outlet side.

## AIR FLOW

The **optimum air flow** for the Newair® tube diffuser is 6-12 Nm<sup>3</sup>/(h x ml). If the air flow rate falls below the optimum range for a longer period of time (approx. 24 hrs.), the flushing of the aerator elements with an air flow rate of 30 Nm<sup>3</sup>/(h x ml) is recommended.

### STORAGE

The aerators must be stored in their original packing in a dry room. During storage the aerators must be protected from damage caused by ambient conditions

(heat, painting, etc.). The aerators and accessories should be installed and put into operation within the usual periods of time (max. 1 year).

### MAINTENANCE

Newair® aerators require only a little service, but they are not maintenance-free. The functioning of the aerators depends on the discharge of air from the porous structure of the aerators. Therefore the structure should be free from sediments and incrustation because these affect or can even prevent the discharge process. As a rule, waste water contains substances

which can cause the formation of sediments, such as carbonates (water hardness), ferric and aluminium salts (precipitants), biological growth, polymers.

For a trouble-free operation it is recommended to dose precipitants and other auxiliary agents with the objective of making sparing use of those according to the technical regulations.

### LIFETIME

The precondition for a long lifetime is that the aerators are used in communal waste water. The composition of existing trade and industrial effluents must comply with the regulations laid down in the latest version of

working sheet ATV A 115.

If the discharge of industrial effluents exceeds a proportion of 20 %, the manufacturer has to be consulted. In addition, the assembly and operating instructions must be adhered to.

### SERVICE

It is in your interest to perform regular controls of the aerator system by using the types of maintenance mentioned above. They help to prolong the lifetime of the aerators.

If necessary, you can send aerators to the

manufacturer in order to obtain an analysis of the condition of the aerators (charge according to time involved). The aerators sent in for this purpose should be rinsed, but not cleaned with a pressure washer.



Since 1983 your partner for wastewater treatment products.  
Proudly Made in Italy.



## CONTACT

**Geoteck-Tierre S.R.L.**

Phone +39 035 810296

TeleFax + 39 035 810296

email: [info@geotierre.com](mailto:info@geotierre.com)

Via Prato Pieve 54, 24060 Casazza (BG) - ITALY

Certified ISO9001:2015

**Geoteck-Tierre SRL**  
Via Prato Pieve 54  
24060 Casazza (BG)  
Italy



Azienda con sistema  
di gestione qualità  
certificato secondo la  
Norma ISO9001:2015

Italia

[geotierre.com](http://geotierre.com)